

TDR2000/3
TDR2000/3P
TDR2010
CFL535G

en

fr

de

nl

Quick Start Guide
Guide de démarrage rapide
Kurzanleitung
Snelstartgids

Megger Instruments Limited, Archcliffe Road, Dover, Kent, CT17 9EN, England

T +44 (0)1 304 502101 F +44 (0)1 304 207342

Part No. 2005-926

TDR20003--TDR2010--CFL535G--2005-926_QS_EN_FR_DE_NL_V02

Printed in England www.megger.com

This instrument is manufactured in the United Kingdom. The company reserves the right to change the specification or design without prior notice.

Megger is a registered trademark

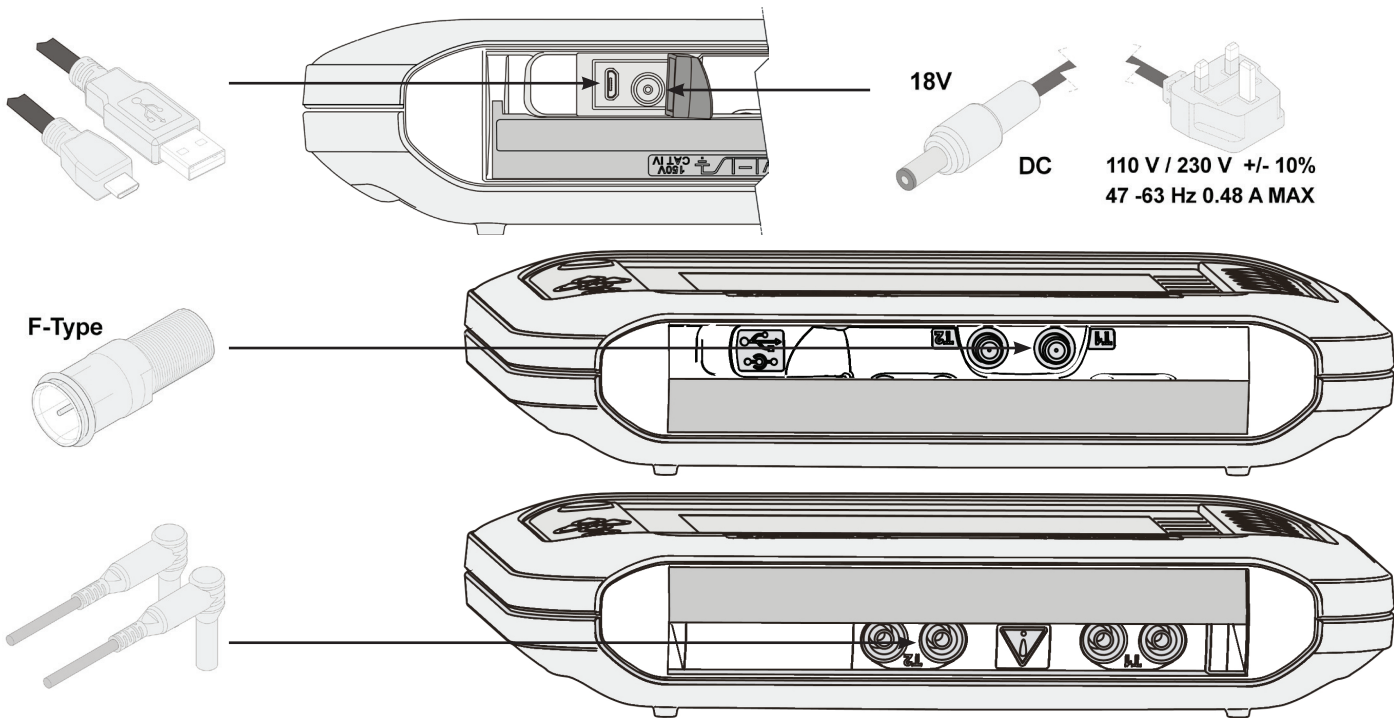

≡ Direct Current - Courant continu - Gleichstrom - Gelijkspanning

⚠ Caution: Refer to accompanying notes
 Attention: Se reporter aux notes qui l'accompagnent
 Vorsicht: Beziehen Sie sich auf die beiliegenden Hinweise
 Försiktighet: Se kompletterande upplysningar

☐ Double insulation - Double isolation - Doppelisolierung - Dubbele isolatie

Li-Ion
 11.1 V, 5.2 Ah



1

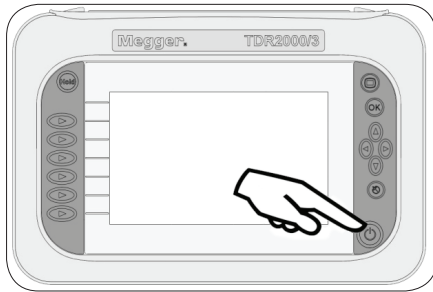

Press and hold to turn TDR on
 Appuyez longuement pour allumer le TDR
 Drücken und halten, um TDR einzuschalten
 Schakel u TDR in door op de aan/uit-knop te drukken



2

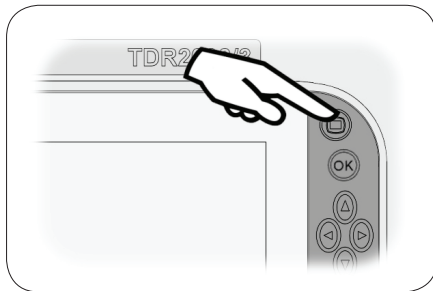

Select mode (Single trace/Dual trace etc.)
 Sélectionnez le mode (Simple trace, double trace, etc.)
 Modus wählen (Einzelner Trace/Doppelter Trace usw.)
 Modus selecteren (Enkele tracing / Dubbele

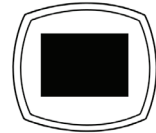

3

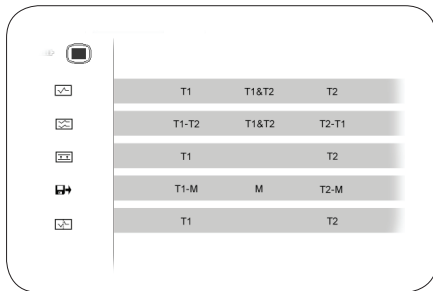

Make your selection using navigation keys
 Faites votre sélection à l'aide des touches de navigation
 Für die Wahl die Navigationstasten verwenden
 Maak uw selectie met de navigatietoetsen

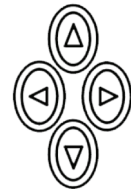

And then... - Et puis ... - Und dann ... - En dan ...

4

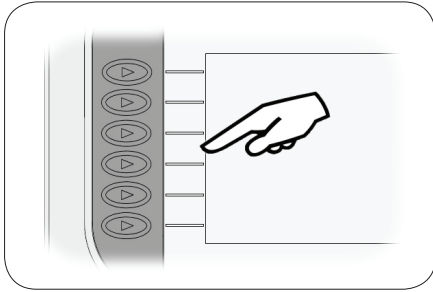

Use a soft key to confirm mode
 Utilisez une touche contextuelle pour confirmer le mode
 Eine Softkey-Taste zur Bestätigung des Modus verwenden
 Gebruik een zachte toets om de modus te bevestigen

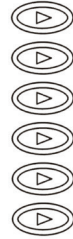

5

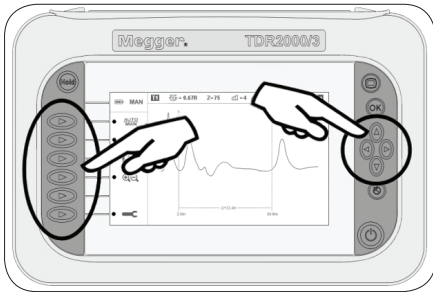

Navigation
 Navigation
 Navigation
 Navigatie

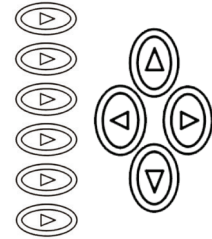

6

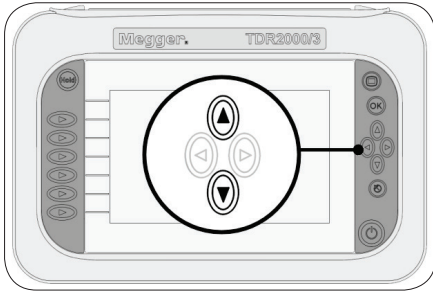

Range
 Plage
 Bereich
 Bereik



7

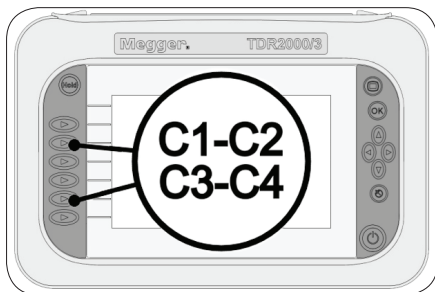

Cursor choice
Choix du curseur
Cursorwahl
Cursorkeuze

C1-C2
C3-C4

8

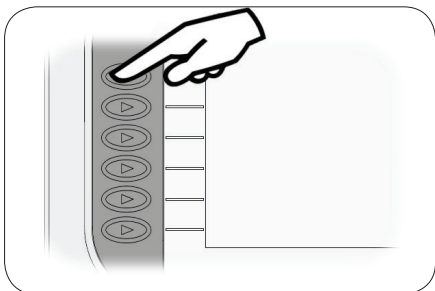

Select Manual/Automatic operation
Sélectionnez le mode manuel ou automatique
Manuellen/Automatischen Betrieb wählen
Handmatig / Automatisch gebruik selecteren

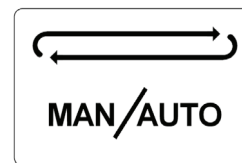

AUTO

In 'Automatic' the instrument detects impedance, pulse width and gain for the connected cable
En mode « Automatique », l'appareil détecte l'impédance, la largeur d'impulsion et le gain du câble raccordé
In „Automatisch“ erfasst das Instrument die Impedanz, die Impulsbreite und die Verstärkung für das angeschlossene Kabel
In 'Automatisch' selecteert het instrument de impedantie, pulsbreedte en toename voor de aangesloten kabel

MAN

For full instructions on Manual operation please see the full user guide CD
Pour des instructions détaillées sur le fonctionnement manuel, veuillez consulter le mode d'emploi complet sur CD
Ausführliche Anleitungen zum manuellen Betrieb sind auf der Benutzerhandbuch-CD zu finden
Zie voor de volledige instructies omtrent het gebruik van de handleiding de CD met de volledige gebruikershandleiding

Automatic operation - Fonctionnement automatique - Automatischer betrieb - Automatische bedienung

Present state shows here
 L'état actuel est montré ici
 Der aktuelle Status wird hier angezeigt
 Huidige statistieken worden hier weergegeven



Settings
 Paramètres
 Einstellungen
 Instellingen

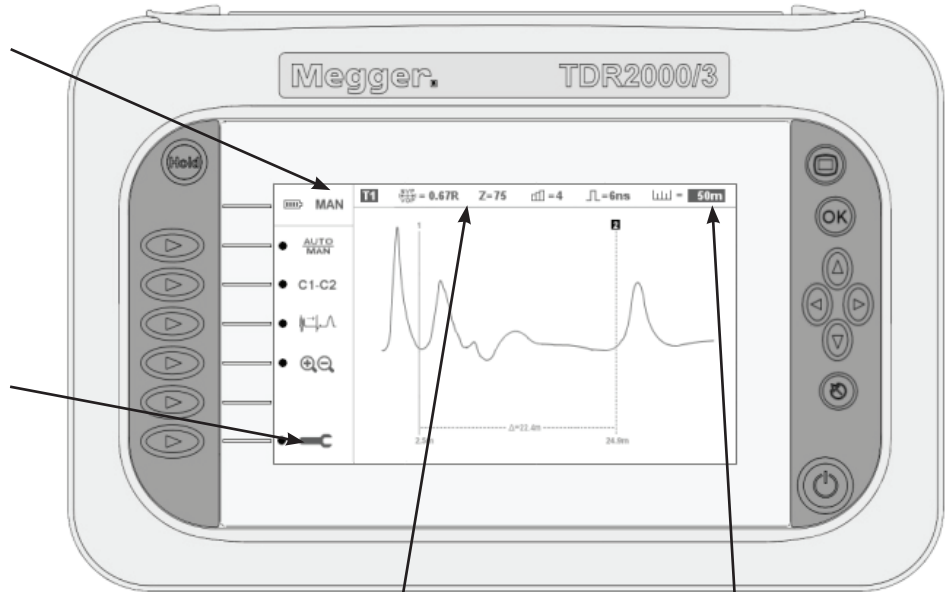

Velocity Factor
 Facteur de vitesse
 Geschwindigkeitsfaktor
 Snelheidsfactor



Cable Range
 Plage du câble
 Kabelbereich
 Bereik kabellengtes

Working with traces - Travailler avec les traces - Arbeiten mit Traces - Traceer cursor keuze

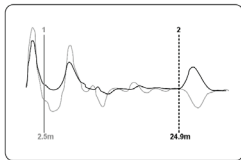

Hold
Attente
Halten
Wachten

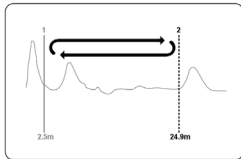

Trace-Cursor choice
Choix du curseur de trace
Trace-Cursor-Wahl
Traceer cursor beweging

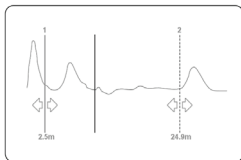



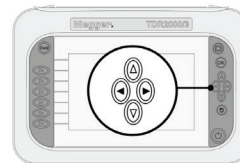
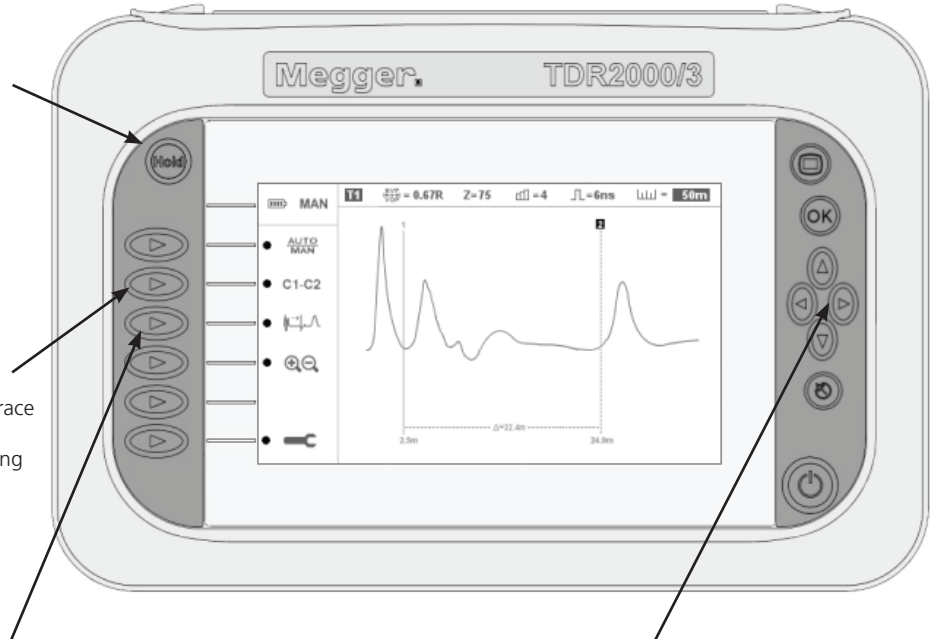



















Expert function (find next fault)
Fonction expert (trouver le défaut suivant)
Experten-Funktion (nächsten Fehler finden)
Expert functie (volgende fout vinden)



Trace-Cursor movement
Mouvement du curseur de trace
Trace-Cursor-Bewegung
Cursorbeweging

Glossary - Glossaire - Glossar - Woordenlijst

	en	fr	de	nl
	Function	Fonction	Funktion	Functie
	Single Channel mode	Mode Single Channel	Single Channel-Modus	Single Channel-modus
	Dual Channel mode	Mode Dual Channel	Dual Channel Modus	Dual Channelmodus
	Intermittent mode	Mode intermittent	Intermittierender Modus	Afwisselende modus
	Crosstalk	Crosstalk	Crosstalk	Crosstalk
	Save	Enregistrement	Speichern	Opslaan
	Load saved trace	Charger la trace sauvegardée	Gespeicherte	Opgeslagen log laden
	Auto Find	Recherche auto	Autosuche	Automatisch zoeken
	Press for next fault	Appuyez pour le défaut suivant	Presse zum nächste suchen	Druk voor de volgende fout
	Zoom function	Fonction zoom	Für den nächsten Fehler drücken	Zoomfunctie
	Delete	Supprimer	Zoomfunktion	Verwijderen
	Accept	Accepter	Löschen	Accepteren
	Preview	Aperçu	Annehmen	Voorbeeld
	Mode	Mode	Modus	Modus

	en	fr	de	nl
	Function	Fonction	Funktion	Functie
C1-C2 C3-C4	Cursor controls	Commandes du curseur	Cursor-Steuerelemente	Cursorbediening
	Settings	Paramètres	Einstellungen	Instellingen
AUTO	Automatic operation	Fonctionnement automatique	Automatischer betrieb	Automatische bediening
MAN	Manual operation	Fonctionnement manuel	Manueller betrieb	Handmatige bediening
	Preferences	Préférences	Präferenzen	Voorkeuren
	Colour scheme	Thème de couleur	Farbschema	Kleurenschema
	Help	Aide	Hilfe	Hulp
	Velocity factor	Facteur de vitesse	Geschwindigkeitsfaktor	Snelheidsfactor
Z	Impedance	Impédance	Impedanz	Impedantie
	Gain	Gain	Verstärkung	Versterking
	Pulse width	Largeur d'impulsion	Impulsbreite	Pulsbreedte
	Range	Plage	Bereich	Bereik
	Edit colour scheme	Couleurs personnalisées	Farben anpassen	Kleuren aanpassen

For local contact and support information see www.megger.com or email support@megger.com

Pour des renseignements sur le contact local et l'assistance, visitez le site www.megger.com ou envoyez un email à support@megger.com

Für Kontakt vor Ort und Support-Informationen siehe www.megger.com bzw. eine E-Mail an support@megger.com schicken

Zie www.megger.com of stuur een e-mail naar support@megger.com voor plaatselijke ondersteuning en informatie